

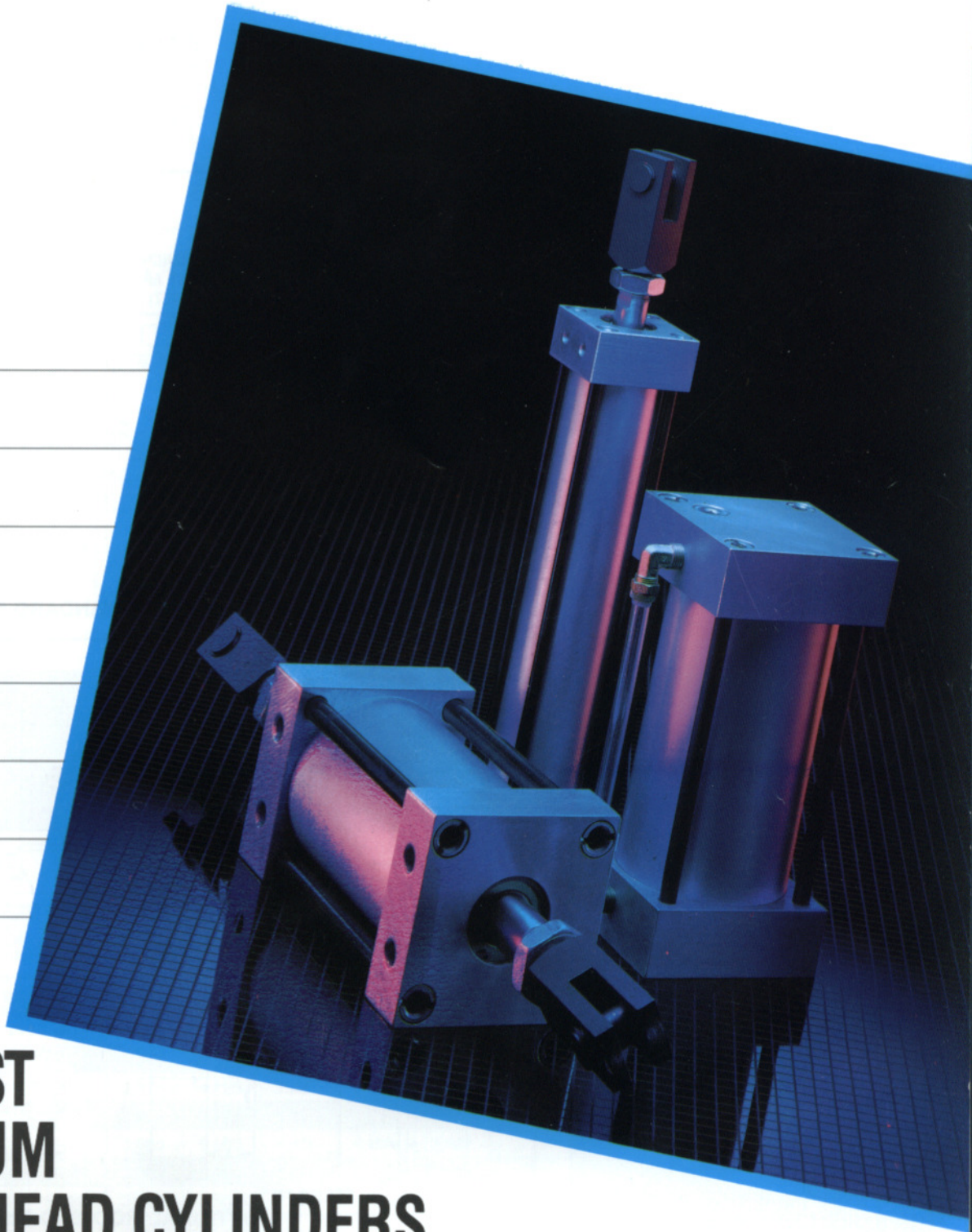

Specialists in Quality
Air Cylinders
and Components



**LOW COST
ALUMINUM
SQUAREHEAD CYLINDERS
& AIR OIL TANKS
250 PSI AIR**

**Series I - 1 $\frac{1}{4}$ " to 5" Bore
Series M - 6" & 8" Bore
Series A - Air Oil Tanks
1 $\frac{3}{4}$ " to 8" Bore**

SERIES "I" & "M" INTERCHANGEABLE CYLINDERS

Features

- Interchangeability
- Pre-lubricated for non-lubricated service
- Low friction teflon piston bearing
- All bronze extended-life rod bearing
- High strength chrome-plated steel piston rod
- Square machined aluminum heads
- Light weight aluminum tubing precision machined to length
- Tubing I.D. hard-coated for corrosion resistance and extended seal life
- Flush mounting holes - front, rear & bottom
- BUNA-N piston and rod seals
- Rubberized tube seal gaskets
- 100% field repairable
- High strength coated steel tie rods

Options

- Stroke lengths to specifications
- Viton seals
- Cushions and bumpers
- Adjustable cushions
- Special rod threads, ports and mounting holes
- Non rotating
- Magnetic pistons and reed switches
- Spring returns
- Stainless steel piston rods
- Several mounts available
- Engineered specials

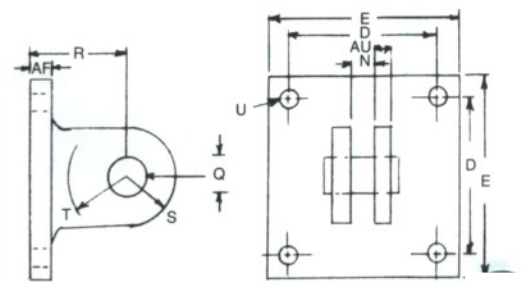
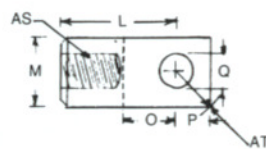
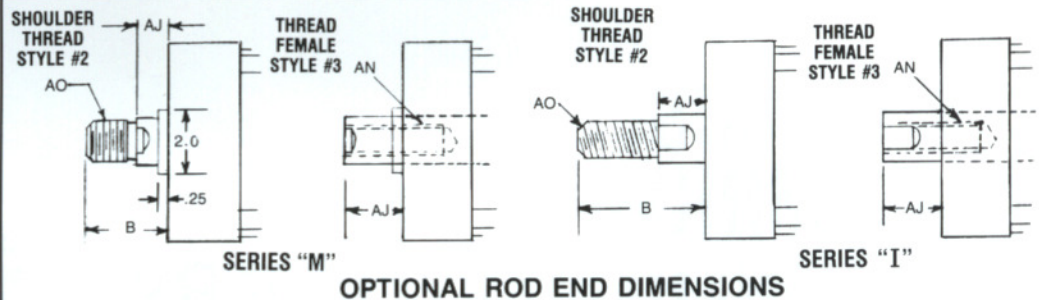
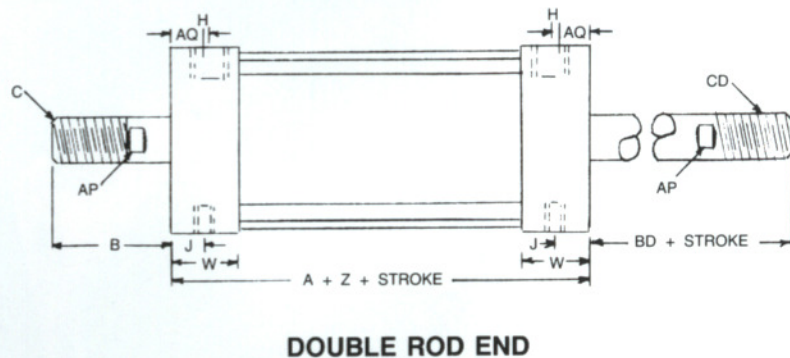
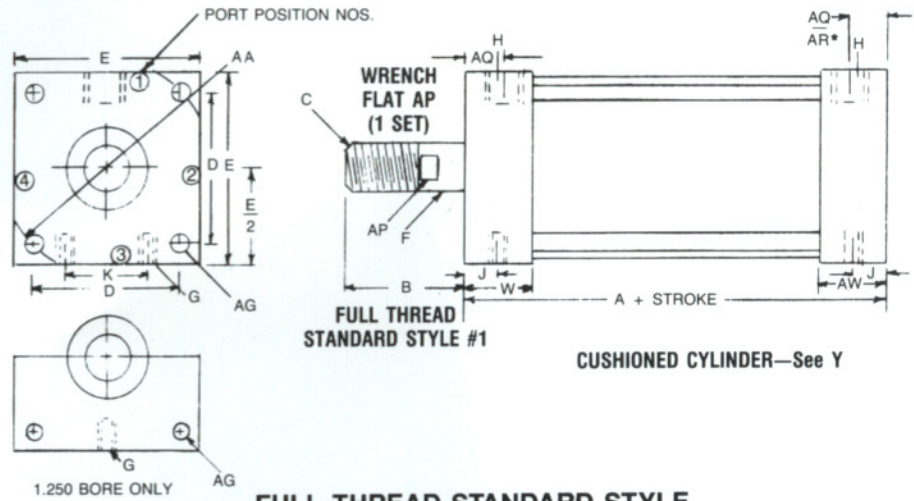

CYLINDERS

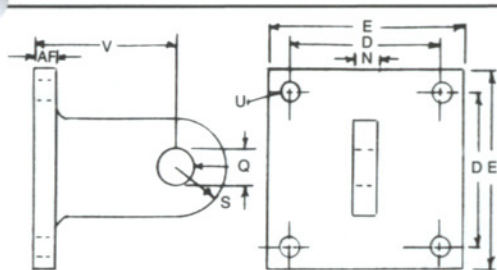

EYE MOUNTS

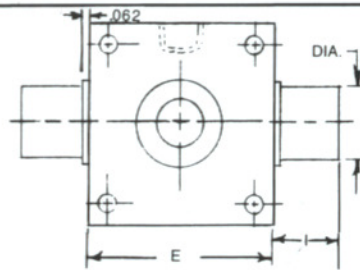

TRUNION MOUNT

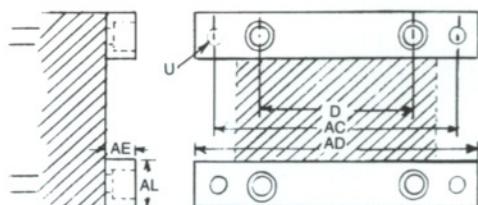
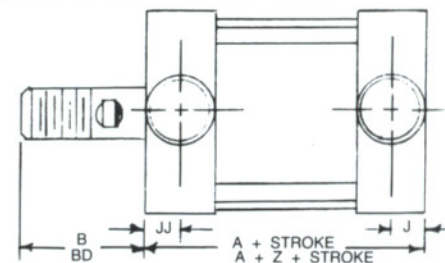

**FLANGE MOUNTS
FRONT OR REAR**

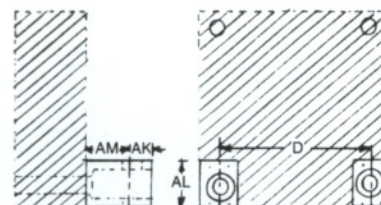

END LUG MOUNTS

SERIES	BORE SIZE	POWER MULTI		A	B BD	C CD	D	E	Rod Dia F	G	H NPT	I	J JJ*	TRN. DIA	K	L	M	N AX*	O	P	Q	R	S	T	U
		Extend	Retract																						
I	1.250	1.23	1.12	2.906	1.625	3/8-16 x 1	1.281	1.813	.375	1/4-28 x 1/4	1/8	.437	.438	.375	—	1.344	.625	.250 .250	.469	.375	.375	1.000	.438	.562	.257
	1.750	2.40	1.96	3.797	2.250	3/4-10 x 1 1/2	1.719	2.375	.750	5/16-24 x 1/4	1/4	.937	.594	1.000	.781	1.891	1.125	.500 .500	.656	.563	.500	1.375	.625	.875	.323
	2.000	3.14	2.70	3.797	2.250	3/4-10 x 1 1/2	1.844	2.500	.750	5/16-24 x 1/2	1/4	.937	.594	1.000	1.000	2.078	1.125	.500 .500	.844	.563	.625	1.437	.813	.973	.323
	2.500	4.91	4.47	3.797	2.250	3/4-10 x 1 1/2	2.206	2.875	.750	5/16-24 x 1/2	3/8	.937	.594	1.000	1.250	2.078	1.125	.500 .500	.844	.563	.625	1.500	.813	1.062	.323
	3.000	7.07	6.62	3.797	2.250	3/4-10 x 1 1/2	2.625	3.375	.750	5/16-24 x 1/2	3/8	.937	.594	1.000	1.250	2.078	1.125	.500 .500	.844	.563	.625	1.812	.813	1.250	.323
	3.500	9.62	8.84	4.545	2.625	1-8 x 1 1/8	3.224	4.125	1.000	1/2-20 x 3/4	1/2	.937	.719	1.000	1.844	2.328	1.250	.500 .500	1.031	.750	.750	2.062	1.000	1.250	.515
	4.500	15.90	15.12	4.545	2.625	1-8 x 1 1/8	4.024	5.125	1.000	1/2-20 x 3/4	1/2	.937	.719	1.000	2.500	2.328	1.250	.500 .500	1.031	.750	.750	2.375	1.375	1.500	.515
	5.000	19.63	18.85	4.797	2.625	1-8 x 1 1/8	4.108	5.500	1.000	1/2-20 x 3/4	1/2	.937	.750	1.000	2.687	2.328	1.250	.500 .500	1.031	.750	.750	2.375	1.375	1.500	.515
M	6.000	28.27	26.50	5.750	2.500	1 1/4-12 x 1 1/8	4.875	6.500	1.500	1/2-20 x 3/4	3/4	.937	.750 1.250*	1.375	3.250	3.000	2.000	1.500 1.000*	1.000	1.000	1.000	2.250	1.000	1.250	.531
	8.000	50.26	48.50	5.750	2.500	1 1/4-12 x 1 1/8	6.440	8.500	1.500	5/8-18 x 3/4	3/4	1.375	.750 1.250*	1.375	4.500	3.000	2.000	1.500 1.000*	1.000	1.000	1.000	2.250	1.000	1.250	.637

SERIES	BORE SIZE	V	W	(1) (2)	Z	AA	AB	AC	AD	AE	AF	AG	(3) AH	AJ	AK	AL	AM	AN	AO	AP	AQ AR*	AS	AT	AU	AW
I	1.250	1.500	.875	1.000	1.000	1.812	.261	2.312	2.750	.375	.250	1/4-28 x 3/8	2.093	.625	.250	.625	.500	1/4-20 x 5/8	1/4-20 x 1	.312	.503 —	3/8-16 x 3/4	.531	.187	.875
	1.750	1.875	1.187	1.000	1.000	2.429	.323	3.031	3.594	.437	.375	5/16-24 x 1/2	3.125	.750	.218	.750	.657	1/2-13 x 3/4	1/2-13 x 1/2	.625	.770 —	3/4-10 x 1	.796	.281	1.187
	2.000	2.000	1.187	1.000	1.000	2.607	.323	3.250	3.750	.437	.375	5/16-24 x 1/2	3.310	.750	.218	.750	.657	1/2-13 x 3/4	1/2-13 x 1/2	.625	.770 —	3/4-10 x 1	.796	.281	1.187
	2.500	2.125	1.187	1.000	1.000	3.119	.323	3.437	4.000	.437	.375	5/16-24 x 1/2	3.310	.750	.218	.750	.657	1/2-13 x 3/4	1/2-13 x 1/2	.625	.695 —	3/4-10 x 1	.796	.375	1.187
	3.000	2.562	1.187	1.000	1.000	3.712	.323	4.062	5.000	.437	.375	5/16-24 x 1/2	3.310	.750	.218	.750	.657	1/2-13 x 3/4	1/2-13 x 1/2	.625	.695 —	3/4-10 x 1	.796	.375	1.187
	3.500	3.000	1.437	1.000	1.000	4.559	.512	5.062	5.937	.625	.375	1/2-20 x 3/4	3.968	1.000	.375	1.000	1.000	3/4-10 x 1 1/8	3/4-10 x 1 1/8	.875	.862 —	1-8 x 1	1.062	.375	1.437
	4.500	3.500	1.437	1.000	1.000	5.690	.512	6.062	7.000	.625	.375	1/2-20 x 3/4	3.968	1.000	.375	1.000	1.000	3/4-10 x 1 1/8	3/4-10 x 1 1/8	.875	.862 —	1-8 x 1	1.062	.375	1.437
	5.000	3.500	1.500	1.000	1.000	5.810	.512	6.562	7.500	.625	.562	1/2-20 x 3/4	3.968	1.000	.375	1.250	1.000	3/4-10 x 1 1/8	3/4-10 x 1 1/8	.875	.862 —	1-8 x 1	1.062	.560	1.500
M	6.000	2.250	2.000	—	.500	6.893	.512	7.625	8.500	.750	.750	1/2-20 x 1/2	3.875	.875	.375	1.625	1.000	★	1 1/4-12 x 1 1/8	1.250	.862 750*	1 1/4-12 x 1 1/4	1.421	.750	1.500
	8.000	2.250	2.000	—	.500	9.100	.512	10.000	11.250	.875	.750	5/8-18 x 3/4	3.875	.875	.500	2.000	1.250	★	1 1/4-12 x 1 1/8	1.250	1.250 750*	1 1/4-12 x 1 1/4	1.421	.750	1.500

(1) Dimension adder per cushion for lengths of 1" and 2" rod end cushion and 1" blind end cushion of single rod end series. "I" Cylinders. Consult factory for longer cushions.

(2) C and CD should be used to differentiate ends of a double rod end unit. Cushion located at CD end requires no adder.

(3) AH distance is minimum distance from cylinder face to centerline of rod clevis pin.

SERIES "I" & "M" PARTS LIST

SERIES 'I' & 'M' STANDARD

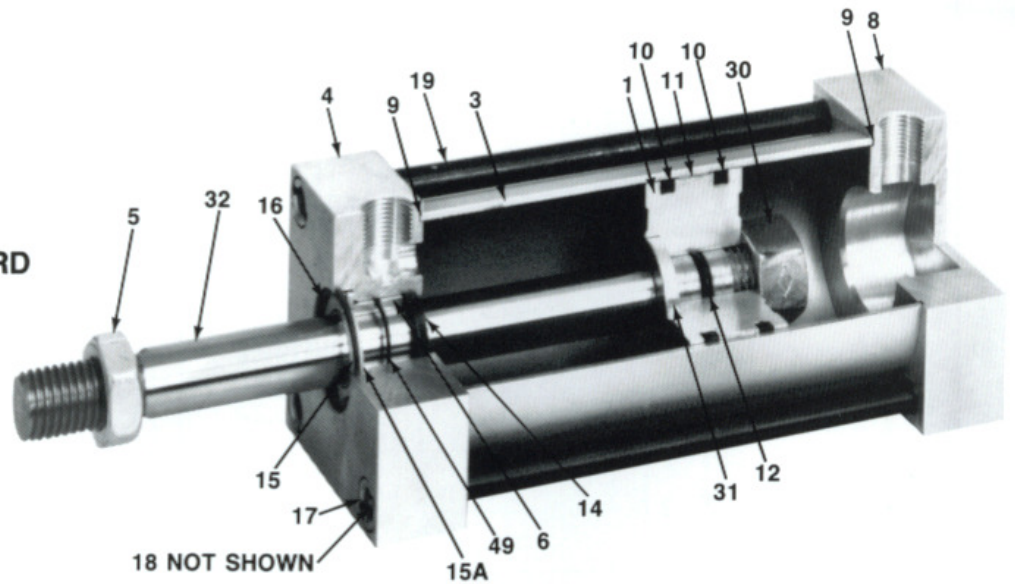

SERIES 'I' DOUBLE CUSHION

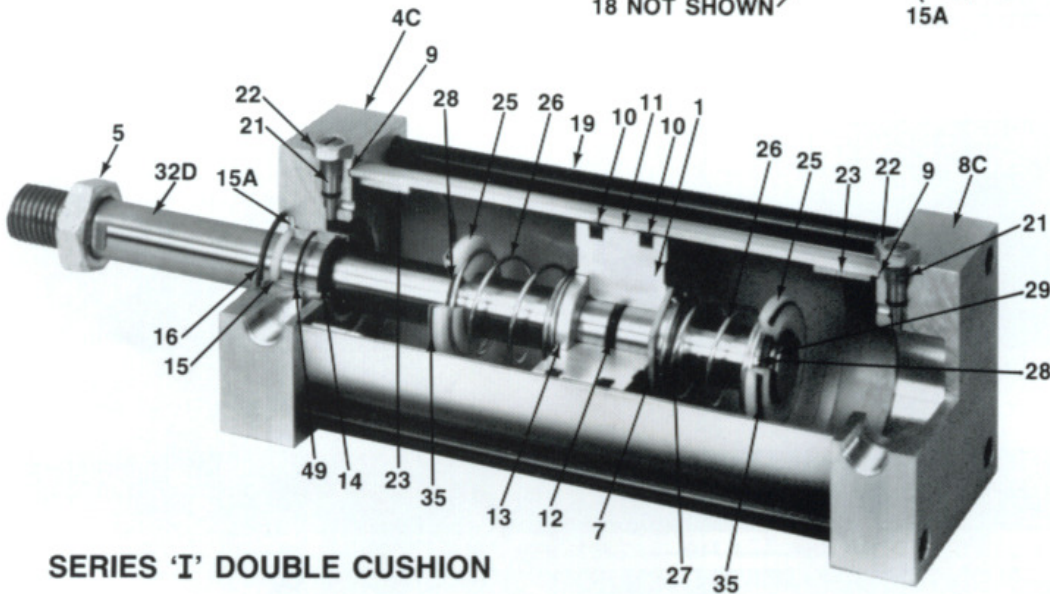

REPAIR KIT INCLUDES

Seals, gasket, bearing strips, rod wipers and bearings.

When ordering please specify:

- Single or Double ended
- Front, Rear or Double Cushion

ITEM	DESCRIPTION	REQUIRED		ITEM	DESCRIPTION	REQUIRED	
		I	M			I	M
1	Piston	1	1	16	Bearing Retaining Ring	1	1
3	Cylinder	1	1	17	Tie Rod Nut	4	4
4	Rod Head	1	1	18	Tie Rod Lock Washer	4	4
4C	Rod Head Cushioned	1	—	19	Tie Rod	4	4
5	Jam Nut	1	—	21	Cushion Screw	1	—
6	Rod Bearing	1	1	22	Cushion Screw Seal Nut	1	—
7	Piston Nut Blind Cushion	1	—	23	Cushion Stop Tube	1	—
8	Blind Head	1	1	25	Cushion	1	—
8C	Blind Head Cushioned	1	—	26	Cushion Spring	2	—
9	Cylinder Seal Gasket	2	2	27	Split Threaded Washer (Cushion)	1	—
10	Piston Seal	2	2	28	Cushion Seal	1/cush	—
11	Piston Glide Strip	1	1	29	Blind End Cushion Retaining Ring	1	—
12	Piston Rod Seal	1	1	30	Piston Retaining Nut	1	1
13	Piston Support Cushioned	1	—	31	Piston Support	1	1 (DI only)
14	Rod Seal	1	1	32	Piston Rod	1	1
15	Rod Wiper	1	1	35	Cushion "O" Ring	1	—
15A	Piston Rod Wiper Retaining Washer	1	—	49	External Bearing Seal	1	1

ORDERING INFORMATION

Please be specific when ordering. The following Springville abbreviations will assist you in ordering.

PREFIX DESIGNATION

- I** – single rod end 1¼" through 5" bore
- DI** – double rod end 1¼" through 5" bore
- DM** – double rod end 6" and 8" bore
- M** – single rod end 6" and 8" bore cylinders
- A** – air oil tanks 1¾" through 8" bore

SUFFIX DESIGNATION

- C** – cushioned both ends
- CB** – cushioned blind end (rear)
- CR** – cushioned rod end (front)
- CM&P** – clevis mount and pin with bolts (rear clevis)
- RC&P** – rod clevis and pin
- EM** – eye mount
- FF** – front flange

EXAMPLE

Standard unit, single rod end

Series I 1¾" bore 4" stroke

I 175 × 4

└─Series └─Bore └─Stroke

Standard unit double end

Series DI 2½" bore 3" stroke clevis mount

DI 250 X 3 CM & P

└─Series └─Bore └─Stroke └─Clevis Mount & Pin

WARRANTY: Please see our industry-leading THREE YEAR LIMITED WARRANTY document.

RETURNED GOODS: All returns must be authorized by Springville Mfg. Co., Inc. Returns must be shipped prepaid, and are subject to a restocking charge. Approval will only be given for unused goods which are stock items.

PRODUCT ENHANCEMENTS: Our continuing product improvement effort may require changes in specifications without notice. This does not affect our interchangeability feature.

PRODUCT LISTING:

- SERIES "I"** 250 PSI Aluminum Square Head Cylinders 1¼" through 5" bore
- SERIES "M"** 250 PSI Aluminum Square Head Cylinders 6" and 8" bore
- SERIES "A"** 250 PSI Aluminum Square Head Air Oil Tank 1¾" through 8" bore
- SERIES "C"** 150 PSI Round Aluminum Short Stroke Cylinders ½" through 4" bore
- SERIES "SB"** 150 PSI Round Aluminum Cylinders 1⅛" through 4" bore

CUSTOM SERVICE: Springville Mfg. Co., Inc. is a full-line, precision machine shop with engineering and production capabilities for special designs and requirements. Contact us for assistance with your custom manufacturing needs.

FAX: Our Fax service (716) 592-9834 receives your communications 24 hours a day. You will be provided with timely service from our office during regular business hours.

DISTRIBUTED BY



Springville Mfg. Co., Inc.

Specialist in Air Cylinders
and Components
P.O. Box 367
8798 North Street
Springville, New York 14141
Phone (716) 592-4957
FAX (716) 592-9834
Email: sales@springvillemfg.com

Fluid Line Components, Inc.

638 S. Rochester Road
Clawson, MI 48017
Phone (248) 583-9070