

• air cylinder accessories are made of carbon steel • burnished for surface smoothness • bright zinc plated for corrosion resistance

accessories

pivot bracket

- for use with pivot cylinders
- cylinders can pivot through 120°
- one-piece construction for strength and ease of cylinder installation/removal
- pivot pin and cotter pin supplied.

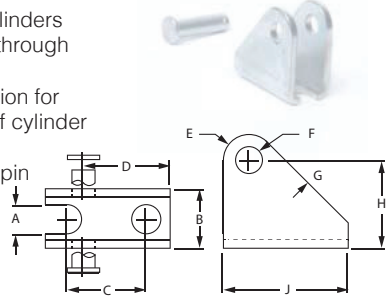

Model Number	Cylinder Bore Sizes (model code)	A	B	C	D	E	F	G	H	J
BP-8-C	1/2 (8)	.20	.52	.43	.54	.22	.16	50°	.64	.75
BP-11-C	3/4 (7) & 1 1/16 (6)	.26	.65	.75	.87	.31	.26	53°	.87	1.19
BP-25-C	1 1/4 (25)	.32	.77	.75	.94	.31	.26	53°	1.06	1.25
BP-15-C	1 1/2 (5) & 1 3/4 (75)	.39	.96	1.00	1.25	.38	.38	52°	1.37	1.63
BP-19-C	2 (4) & 2 1/2 (3)	.45	1.20	1.00	1.43	.38	.38	48°	1.68	1.81

rod clevis

- for use on all cylinders
- smooth beveled ends
- locknut, clevis pin and cotter pin supplied.

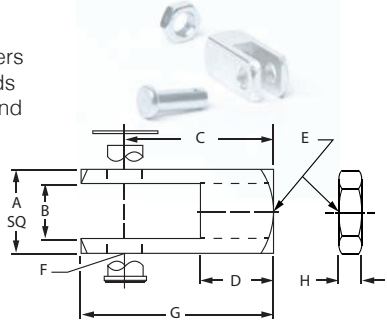

Model Number	Cylinder Bore Sizes (model code)	A	B	C	D	E	F	G	H
CT-8	1/2 (8)	.38	.19	.75	.38	10-32	.19	.94	.12
CT-7	3/4 (7)	.50	.25	.94	.50	1/4-28	.26	1.20	.16
CT-11	1 1/16 (6)	.50	.26	.94	.50	5/16-24	.26	1.20	.19
CT-15	1 1/4 (25) & 1 1/2 (5)	.75	.38	1.30	.75	7/16-20	.38	1.70	.25
CT-19	1 3/4(75), 2(4), 2 1/2(3)	.75	.38	1.30	.75	1/2-20	.38	1.70	.31

foot mount

- for nose mounting and double - end mounting
- gusseted for added strength

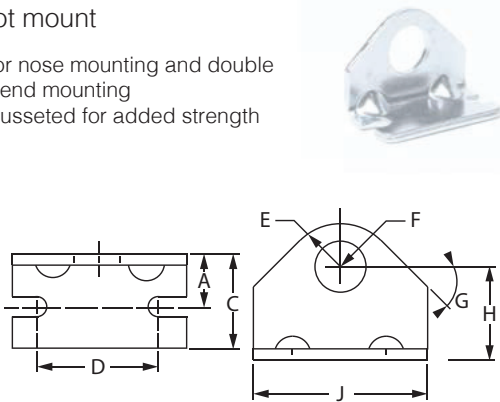

Model Number	Cylinder Bore Sizes (model code)	A	B	C	D	E	F	G	H	J
F-8-S	1/2(8) single acting types	.31	.19	.62	1.00	.37	.38	56°	.57	1.38
F-8	1/2(8) double acting types	.31	.19	.62	1.00	.37	.44	56°	.57	1.38
F-7	3/4(7) single acting types	.44	.19	.75	1.25	.40	.50	45°	.69	1.63
F-11	3/4(7) double acting 1 1/16(6) single & double acting types	.56	.27	1.00	1.50	.56	.63	45°	.81	1.88
F-15	1 1/4(25) & 1 1/2(5) All Types	.77	.27	1.50	1.89	.76	.76	49°	1.00	2.50
F-75	1 3/4(75) All Types	.94	.34	1.50	2.25	.88	1.04	52°	1.25	3.00
F-19	2(4) All Types	1.00	.34	1.62	2.25	1.00	1.38	60°	1.50	3.12
F-21	2 1/2 (3) All Types	1.00	.34	1.62	2.88	1.25	1.50	63°	1.75	3.75

*Model 8-SP requires one each JN-8-S and JN-8 for double end mount.

**Models 7-SP and 7-SHP require one each JN-7 and JN-11 for double end mount.